

Vibrating Discharger

AMVD

Function:

- Discharging powdered materials (dusty products) from reinforced concrete, metal or fiberglass silos
- Particular shape of both bottom and top of the diaphragm, the suspension system, the intensity and the frequency of vibrations are the result of a long experience and ensure a continuous smooth flow of every type of bin .

Main Features:

- No bridging
- Rat-holing elimination
- No erratic flow in discharge
- Complete discharge of the blend
- Possibility of application on existing bins
- Low cost of operation and maintenance
- Noiseless operation and high reliability
- Standard construction in painted carbon-steel

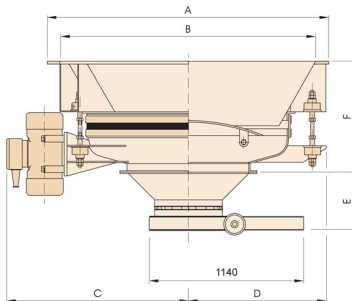

Ard Machine Vibrating Discharger

Type	Dimensions [mm]						Motor (50 Hz) [kW]	Net Weight [kg]
	A	B	C	D	E	F		
AMVD 1500	1715	1615	1085	920	425	615	0.9	565

ARD MACHINE
manufacturing company

Head office: Vall-e-Asr Ave. No.1050/6 - Seventh Floor
No.702 - Post Code: 14338 - Tehran - Iran
Tel.: +98 21 88713695 & 7 Fax: +98 21 88713685

Factory: Qazvin Industrial Zone
Tel.: +98 282 222 30 29
Fax: +98 282 222 30 19

E-mail: info@ardmachine.com
Web Site: www.ardmachine.com