

Feeder

AMRF

Function

- Discharging the materials from the stock bins.

Main Features

- Discharging the materials from the bins using a rotor.
- Being efficiently powered by a very special gear-electric motor.
- The amount of discharging material is controlled by a slide valve.

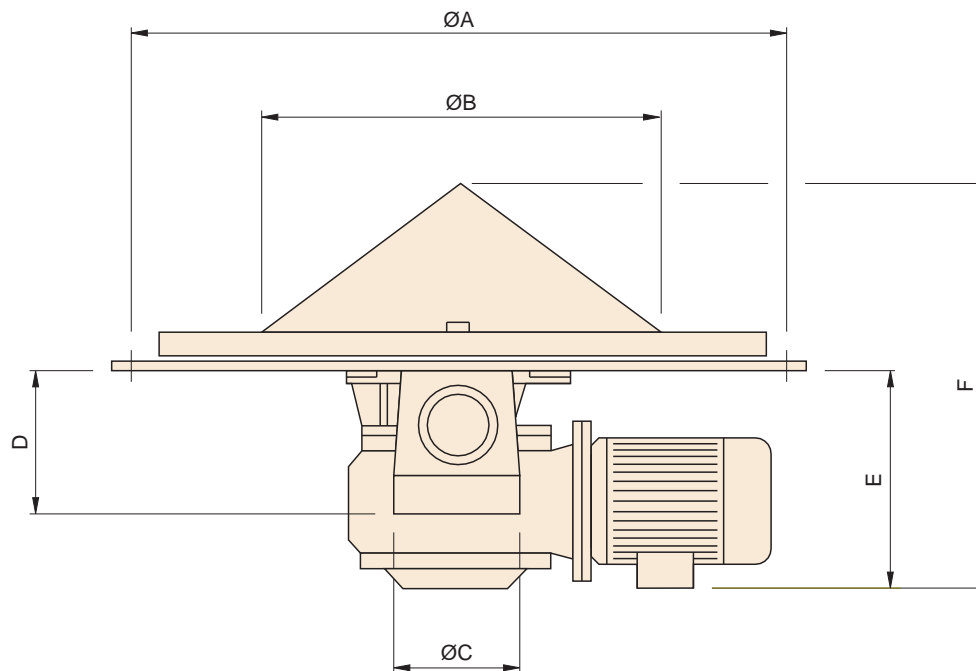

Ard Machine Feeder

Type	Capacity [t/h]	Motor (60 Hz) [kW]	Dimensions [mm]						Net weight [kg]	Shipping volume [m ³]
			ØA	ØB	ØC	D	E	F		
AMRF 500	0.5	1.8	550	305	120	166	245	600	110	0.16

ARD MACHINE
manufacturing company

Head office: Vali-e-Asr Ave. No.1050/6 - Seventh Floor
No.702 - Post Code: 14338 - Tehran - Iran
Tel.: +98 21 88713695 & 7 Fax: +98 21 88713685

Factory: Qazvin Industrial Zone
Tel.: +98 282 222 30 29
Fax: +98 282 222 30 19

E-mail: info@ardmachine.com
Web Site: www.ardmachine.com