

# Flaking Roller Mill

AMFR

- The base is welded together using strong steel plates
- The rollers are manufactured from chilled cast iron with a surface hardness of ~500 Brinell
- The rollers are provided with self aligning roller bearings
- The weight of machine is 6100 kg
- With drive motor
- Each roller arm is provided with a hole for oil cooling
- An electro-hydraulic single block provides the pressing on respectively the lowering of the rollers
- All parts coming into contact with the product are made in stainless steel
- For pressing pre-cooked maize and producing maize flakes

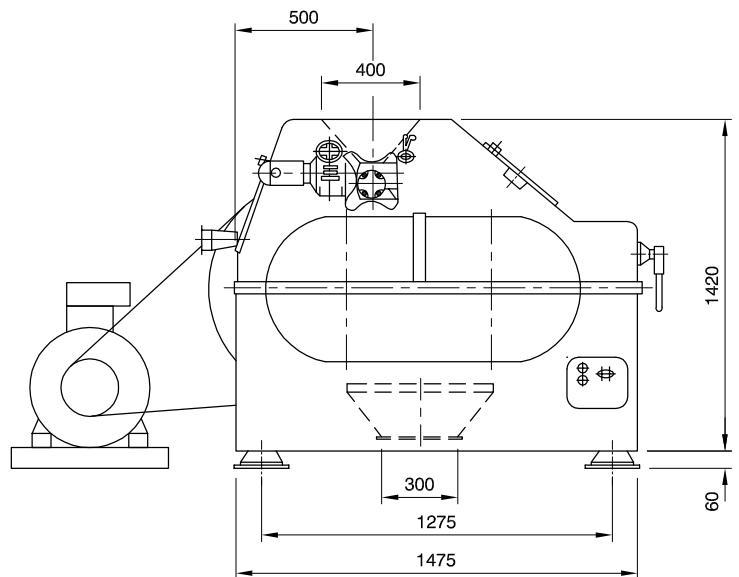
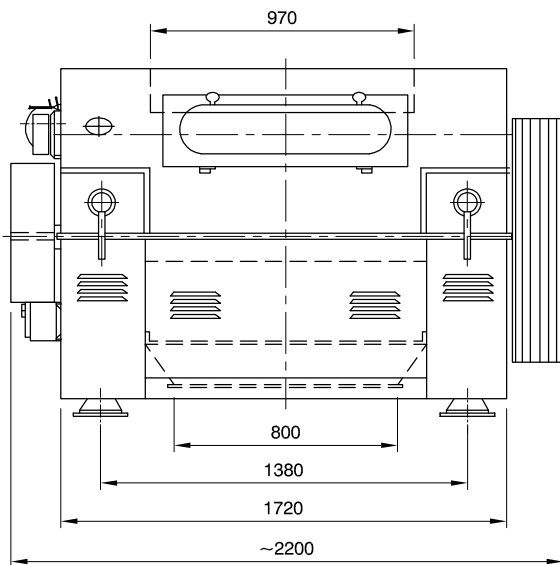

**ARD MACHINE**  
manufacturing company

Head Office: Vali-e-Asr Ave. No.1050/6 - Seventh Floor  
No.702 - Post Code: 14338 - Tehran - Iran  
Tel.: +98 21 88713695 & 7 Fax: +98 21 88713685

Factory: Qazvin Industrial Zone  
Tel.: +98 282 222 30 29  
Fax: +98 282 222 30 19

E-mail: [info@ardmachine.com](mailto:info@ardmachine.com)  
Web Site: [www.ardmachine.com](http://www.ardmachine.com)