

Atomizing Damper

AMAD

Function

- The machine has three parts consisting of load entrance, sprinkler nozzles and control part.
- Water is sprinkled on product by compressed air.

- Sprinkler nozzles can be installed on the screw conveyor.
- By stopping the entrance of load into the screw conveyor, the compressed air and water flow is ceased.

Main Features

- Used for rapid and even moisture distribution along the bran coat of the wheat kernel prior to grinding process, resulting in low ash content flour and large bran articles.

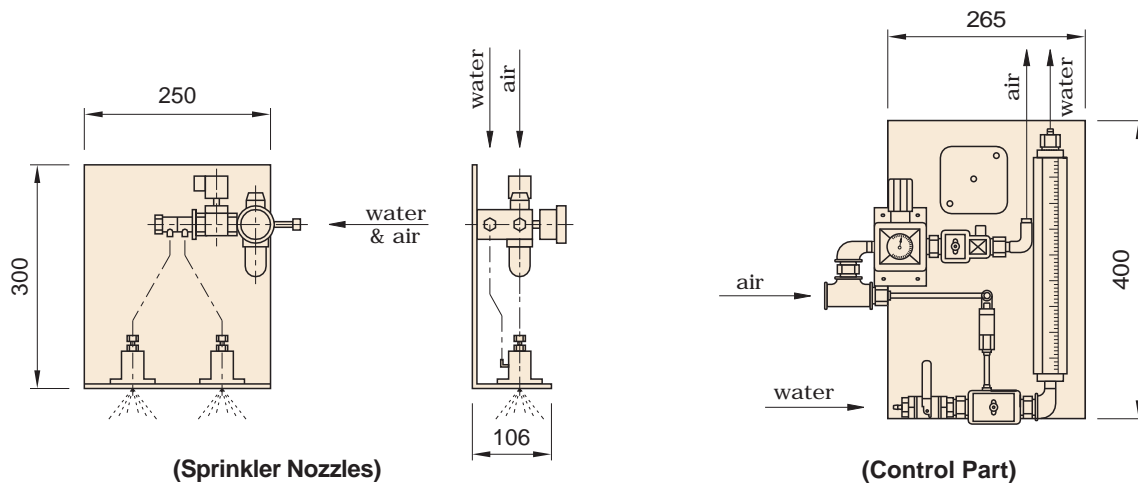
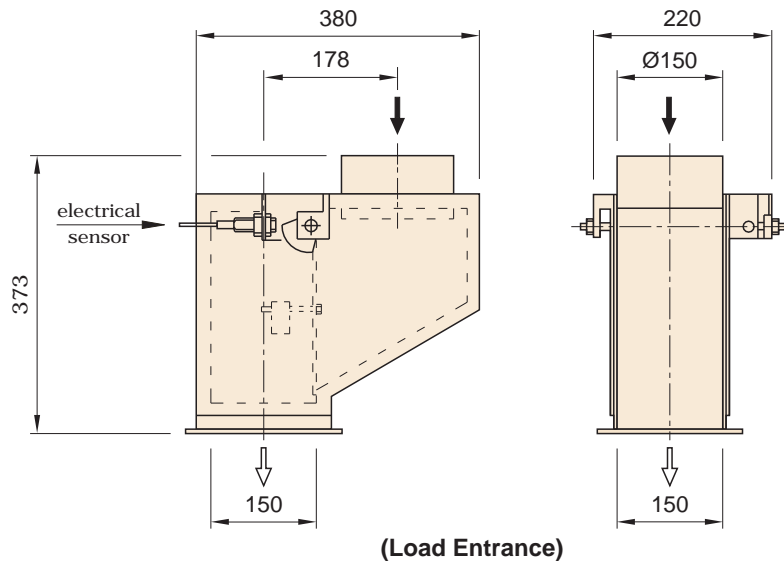

Ard Machine Atomizing Damper

Type	Air pressure [bar]	Compressed air consumption [l/min]	Water flow rate max. [l/h]	Net weight [kg]	Shipping volume [m ³]
AMAD	6	200	90	25	0.2

ARD MACHINE
manufacturing company

Head office: Vali-e-Asr Ave. No.1050/6 - Seventh Floor
No.702 - Post Code: 14338 - Tehran - Iran
Tel.: +98 21 88713695 & 7 Fax: +98 21 88713685

Factory: Qazvin Industrial Zone
Tel.: +98 282 222 30 29
Fax: +98 282 222 30 19

E-mail: info@ardmachine.com
Web Site: www.ardmachine.com